



Distribution Planning Advisory Group

Attachment K Study Development Meeting

DPAG 1 – March 2025

John Gross, P.E. Manager, System Planning

Agenda & Meeting Etiquette

Agenda

- Introductions and Logistics
- Study Development Meeting (Attachment K)
- Transmission Planning Assumptions & Criteria
- Distribution Planning Assumptions & Criteria
- Future Meeting Topics
- Questions & Discussions

Meeting Etiquette

- Meetings will be recorded & posted
- Mute speakers & cameras optional
- Questions in the chat or use the “raise hand” feature
- Respect diverse opinions

Presenters & Topics



April Spacek
System Planning Engineer



Eric Lee
Principal Engineer System Planning

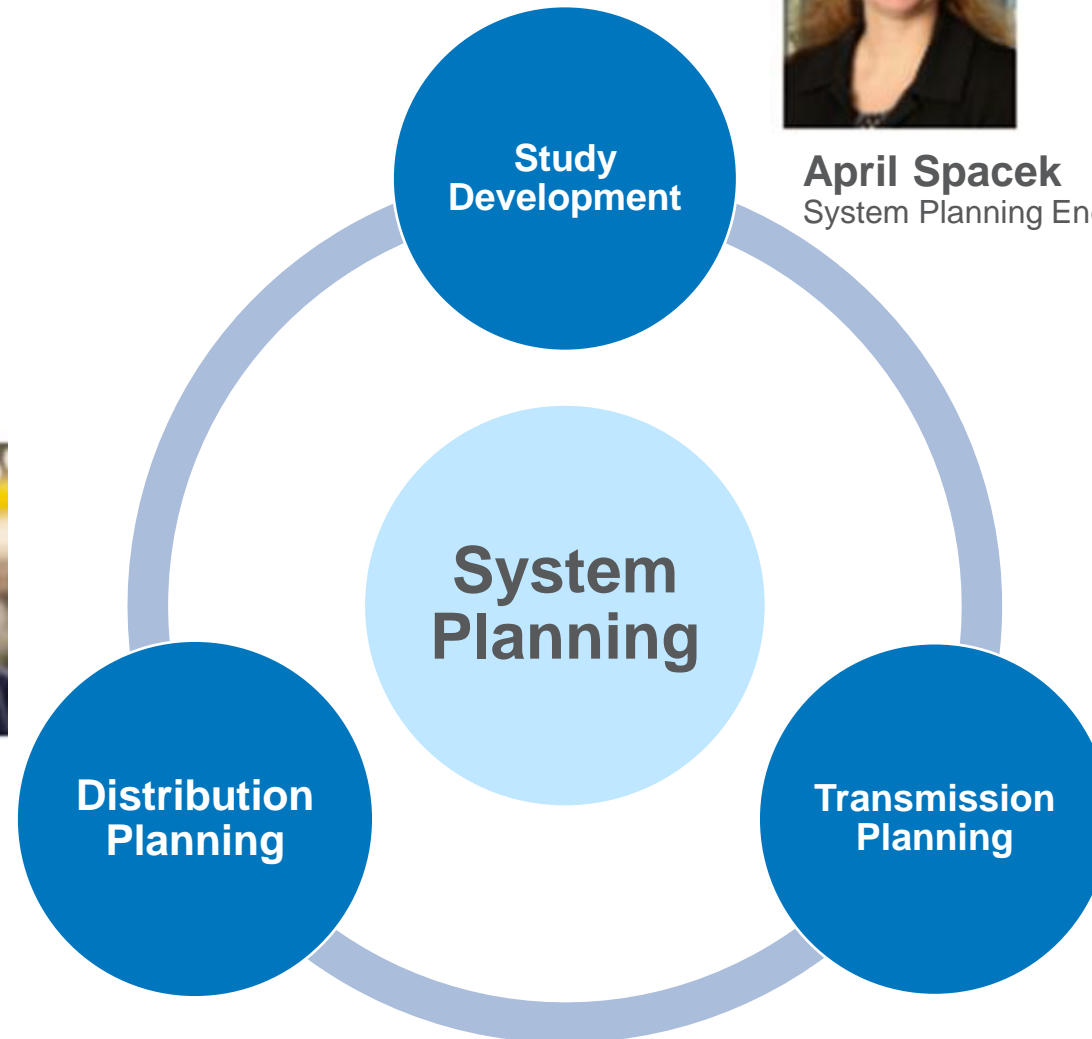

Cole Youngers
Sr. System Planning Engineer

DPAG/Attachment K

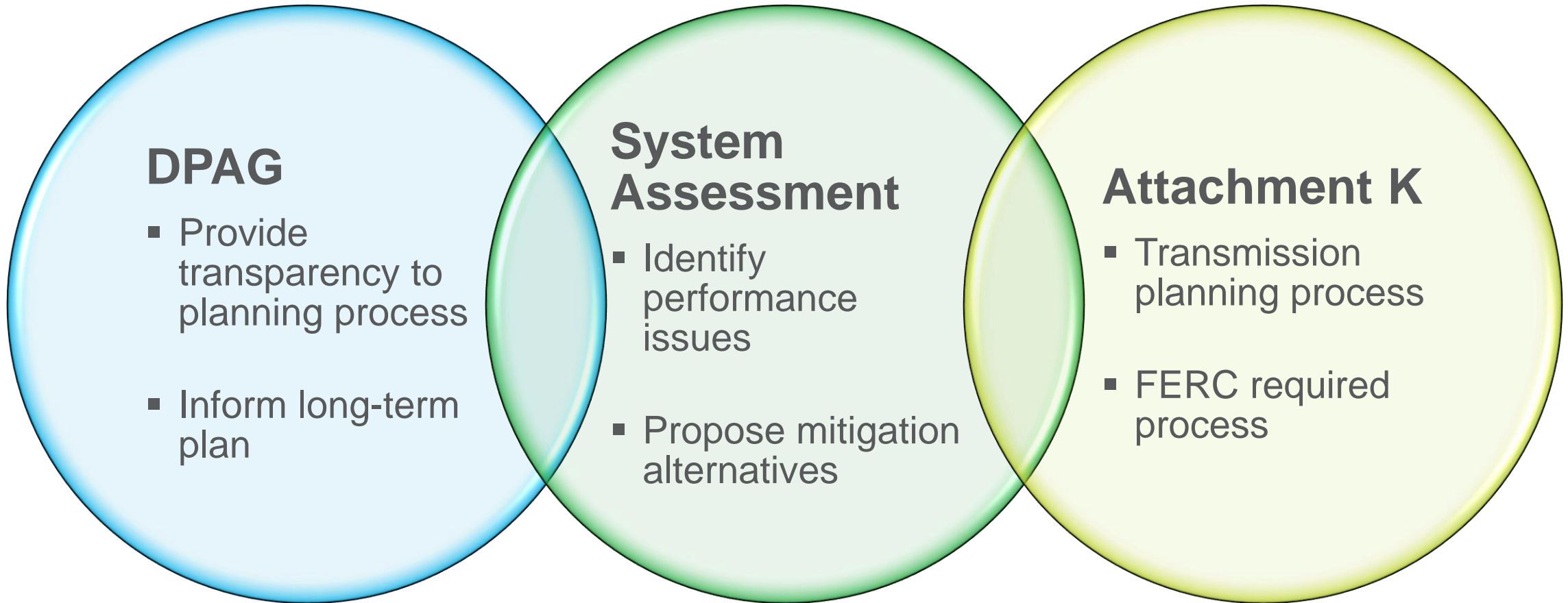

Study Development

Avista's Open Access Transmission Tariff – Attachment K

April Spacek | System Planning Engineer

Study Development



Transmission Planning Process – Attachment K

- Local Planning
- Regional Planning – NorthernGrid
- Interregional Planning – WECC

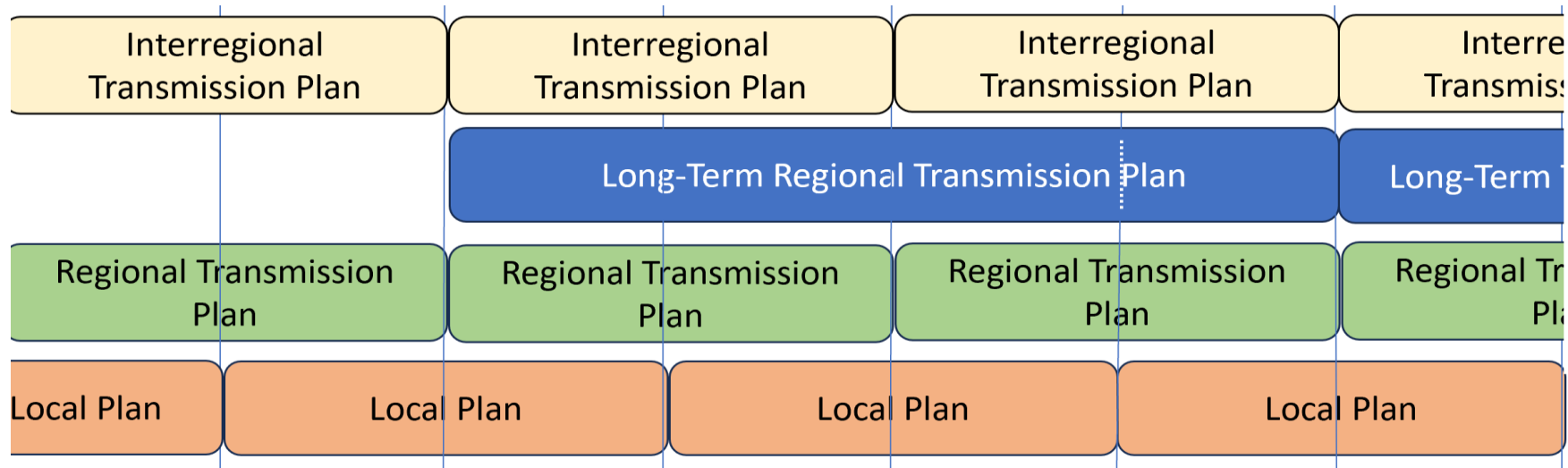

Local Transmission Plan Cycle

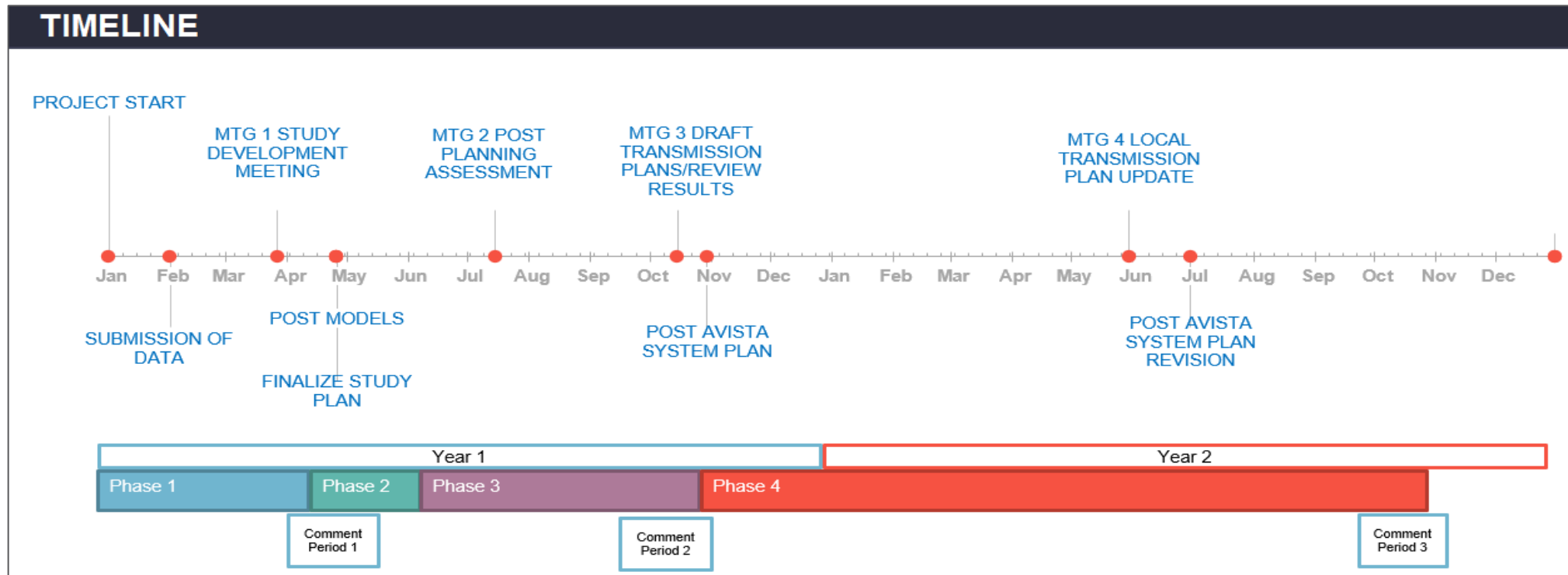

System Planning Assessment Timeline

Avista's Planning Cycle

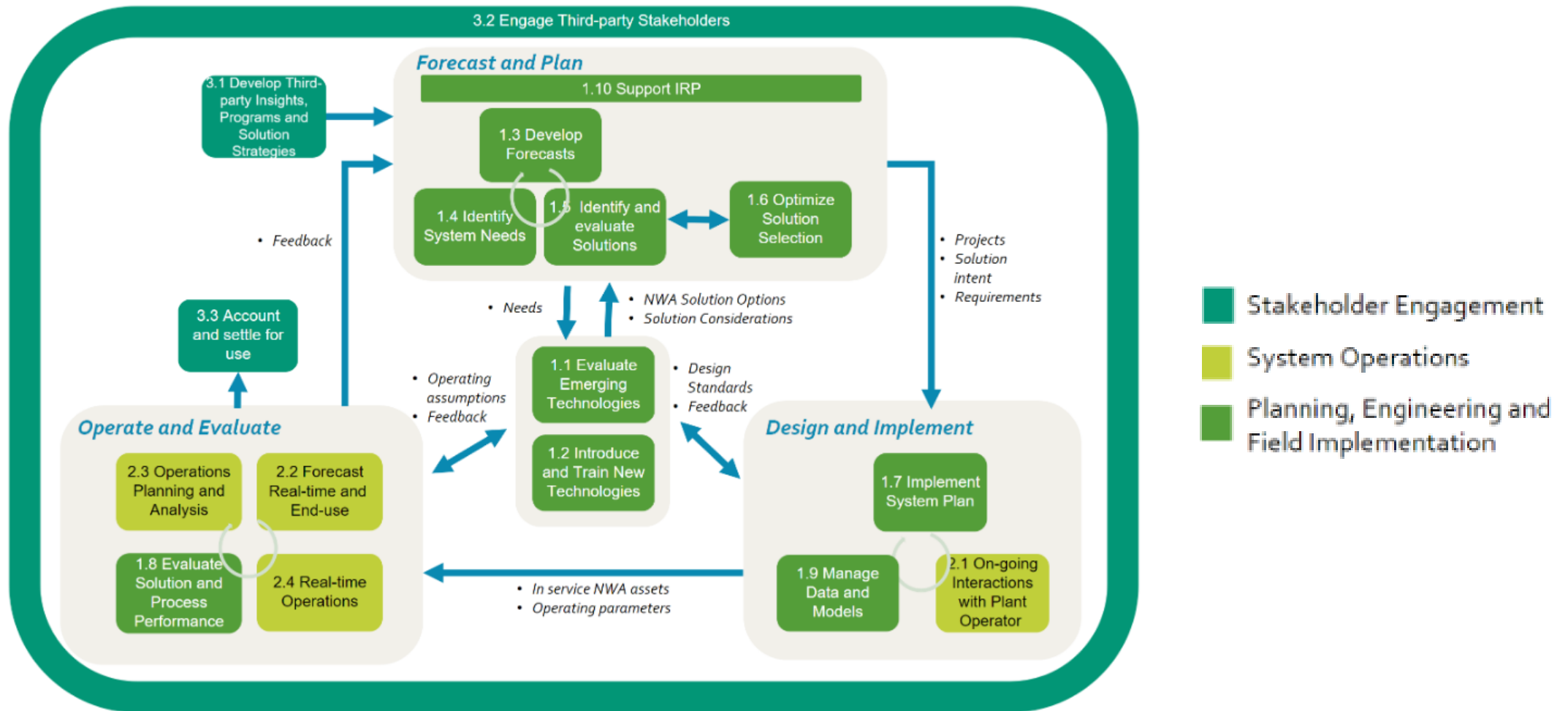

Long Term Regional Planning (FERC 1920)

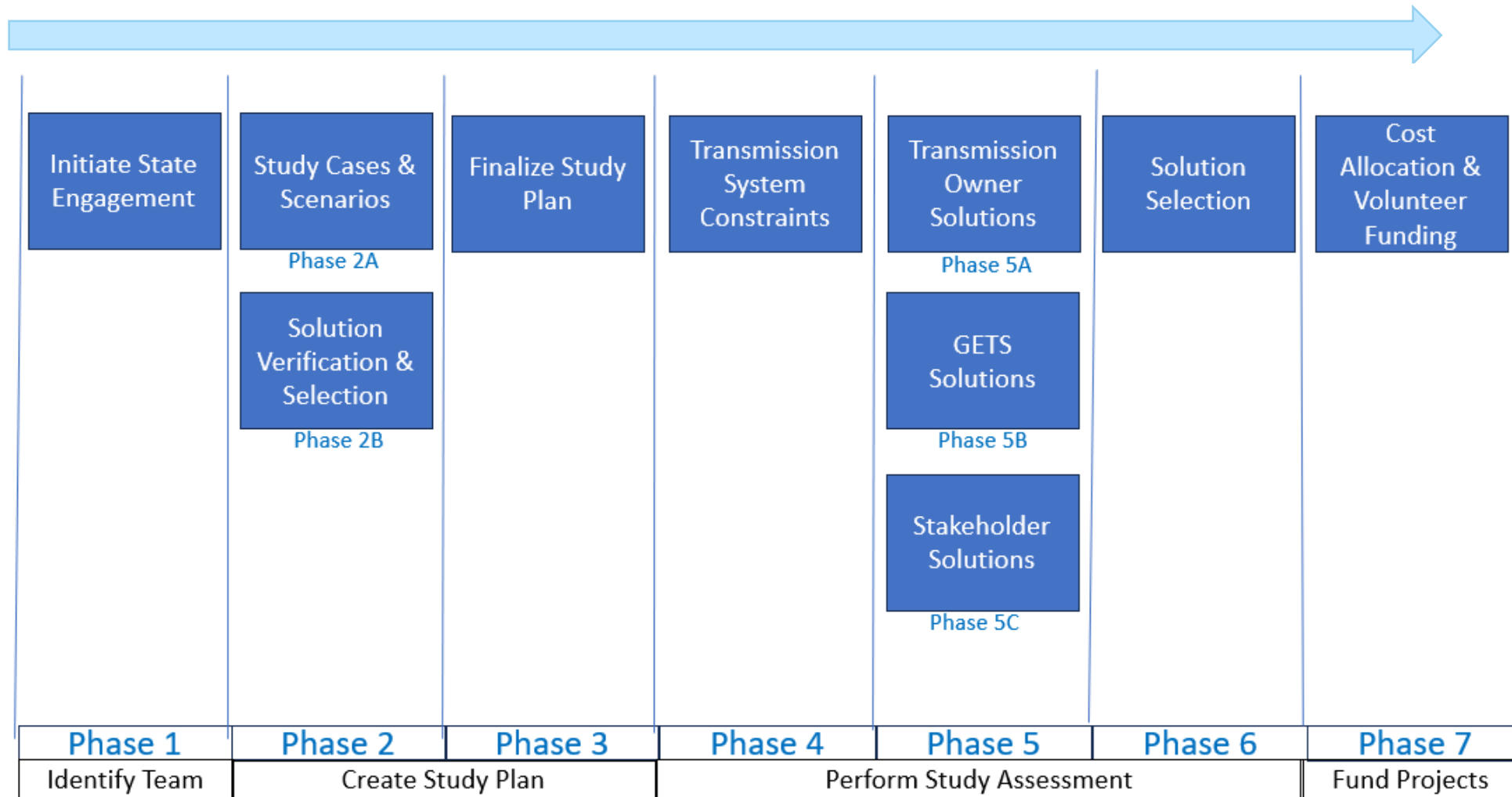

Enhanced Reliability Upgrades

Transmission customers can request upgrades not identified through technical studies.



Avista's 230 kV (left) and BPA's 230 kV line across the Rathdrum Prairie, ID

Transmission Planning

Assumptions, Criteria and Analyses

Cole Youngers | Sr. System Planning Engineer

Initial Assumptions



Study Scenarios

1, 5, and 10 year
Seasonal, heavy and light conditions
Sensitivities



Peak & Off-Peak Load Forecasts

1, 5, and 10 year



Resource Models

Including known future resources (OATT)



Northwest Area Projects

Latest network topology
Planned projects in study horizon
Network expansion projects and firm transmission obligations

Study Scenarios

Scenario	Description (likelihood or "return time")	1 Year (2026)	5 Year (2030)	10 Year (2035)	TPL
Heavy Summer	Loads 1 in 10*, Generation per Generation Dispatch**	X	X	X	R2.1.1, R2.2.1, R2.4.1, and R2.5
Light Summer	Loads 1 in 2*, Generation per Generation Dispatch**	X			R2.1.3 and R2.4.2
Heavy Winter	Loads 1 in 10*, Generation per Generation Dispatch**		X		R2.1.1, R2.2.1, R2.4.1 and R2.5
Heavy Spring	Sensitivity to high load during the spring		X		R2.1.3 and R2.4.3 sensitivity for R2.1.2 and R2.4.2
Light Spring	Loads 1 in 2*, Generation per Generation Dispatch**		X		R2.1.2 and R2.4.2
High E-W Transfer	Sensitivity to light load, high generation, and high system transfers		X		R2.1.3 and R2.4.3 sensitivity for R2.1.2 and R2.4.2

Inputs to the Combined Load Forecast

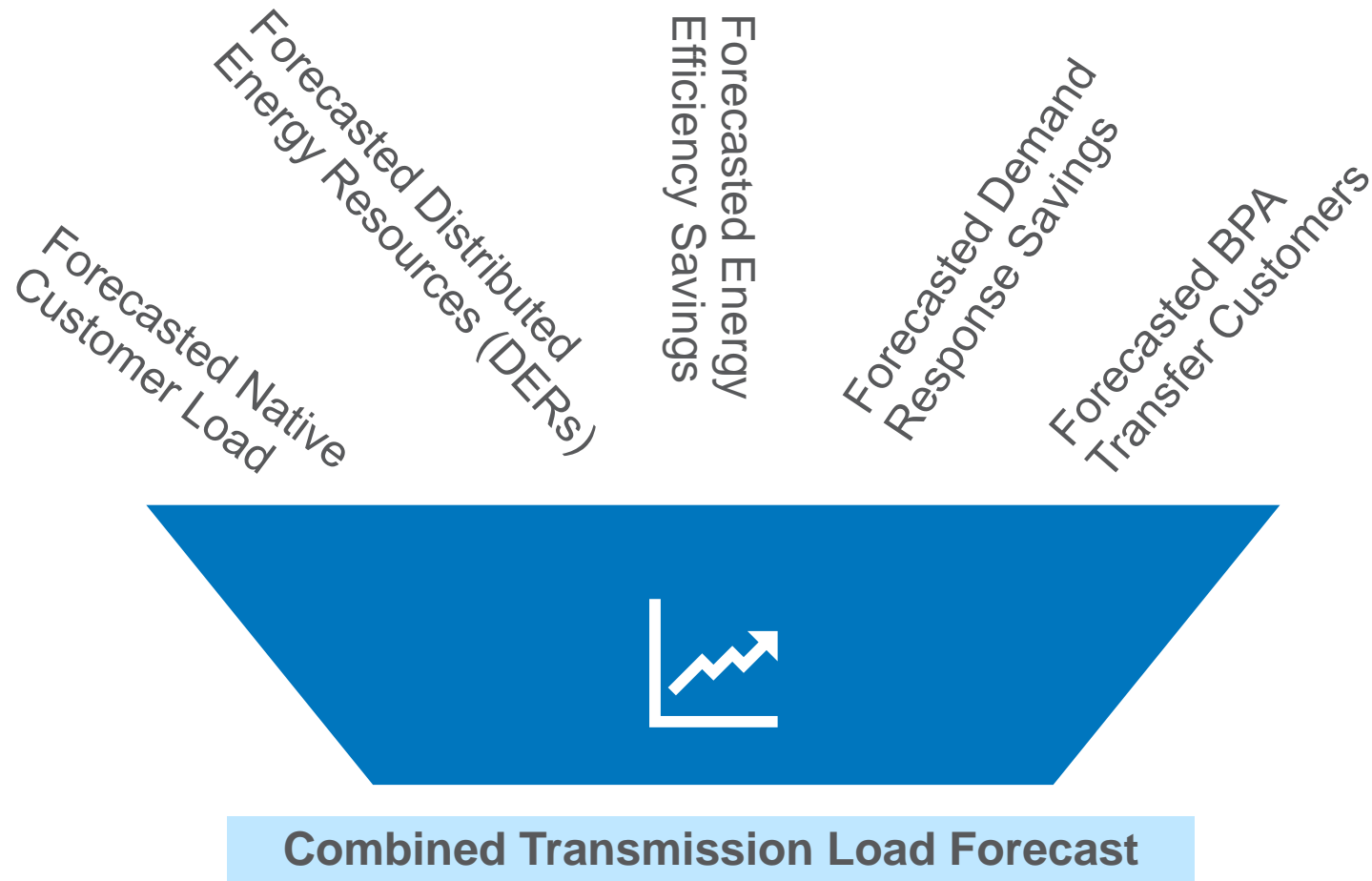

Winter BA Load Forecast

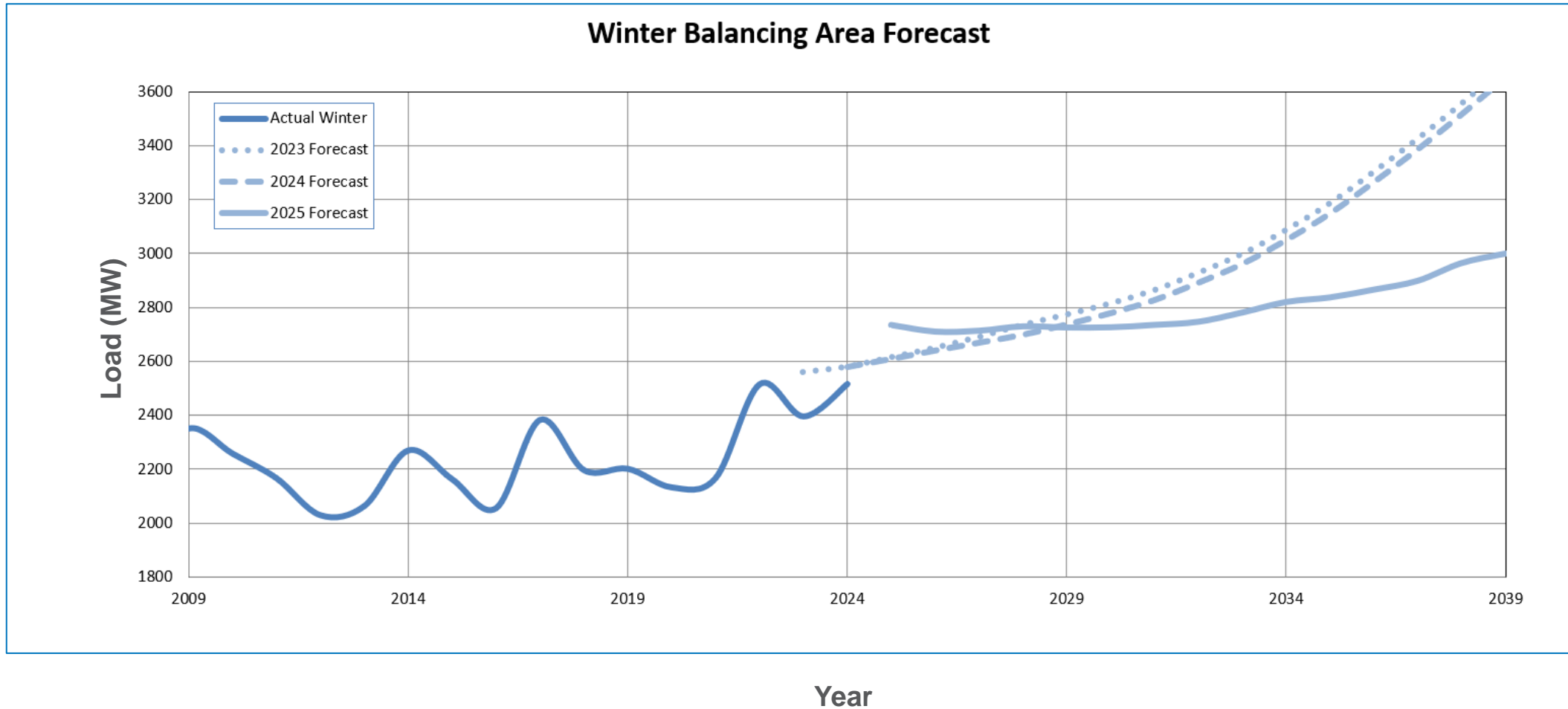

Summer BA Load Forecast

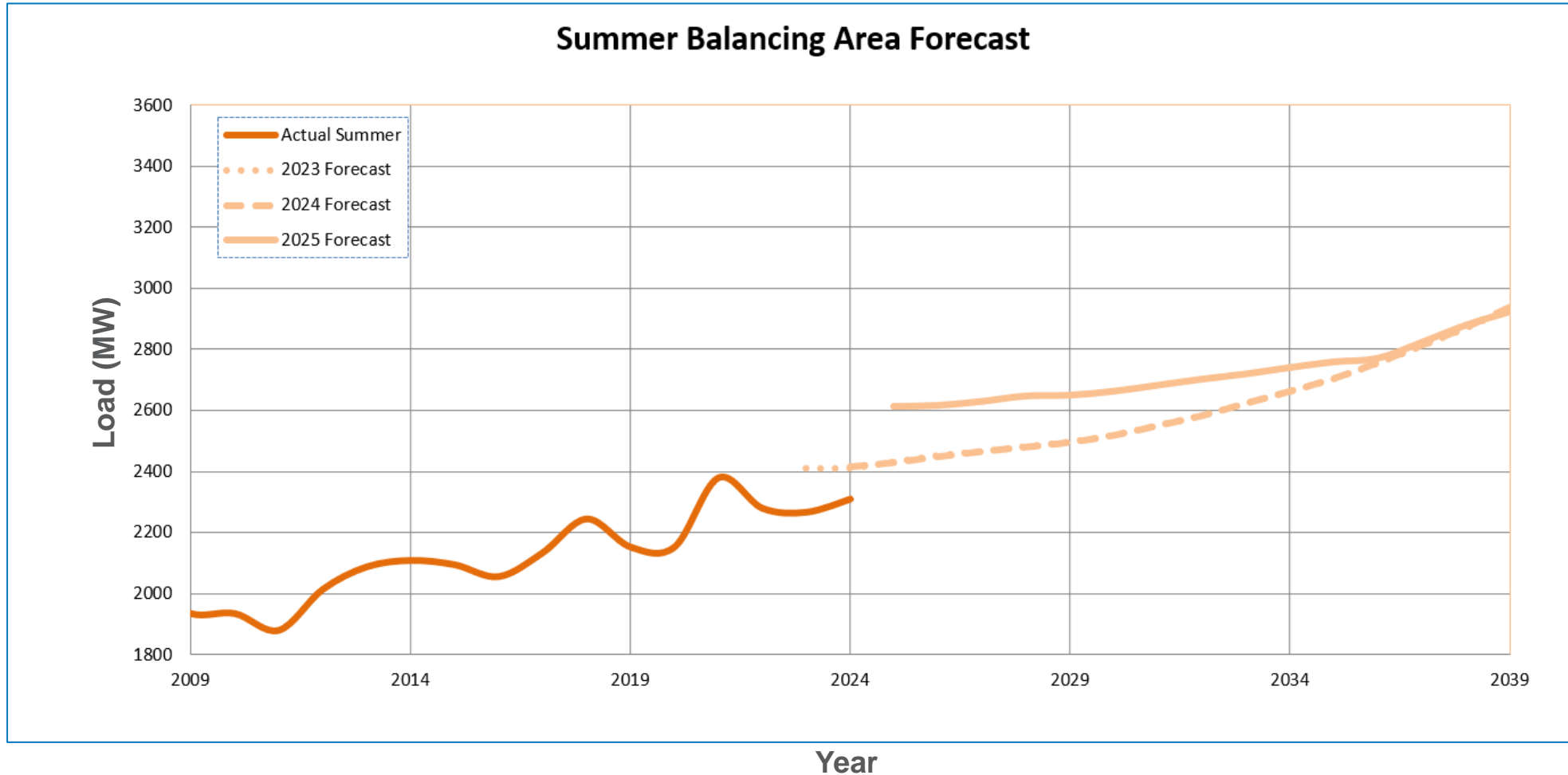

Resource Assumptions

- **Existing Resources**
 - Dispatched seasonally based on historical trends
- **Future Resources**
 - Signed interconnection agreements in study horizon
 - Dispatched seasonally
 - Includes identified transmission upgrades



Avista's Nine Mile Dam, Spokane, WA

Generation Interconnections

Queue #	COD	MW Output	Type	County	State	POI
59	9/1/2027(Susp)	60	Solar/Storage	Adams	WA	Roxboro 115kV Station
60	9/1/2025(Susp)	150	Solar/Storage	Asotin	WA	Dry Creek 230kV Station
97	12/31/2025(Susp)	100	Solar/Storage	Nez Pierce	ID	Lolo 230kV Station
TCS-03	9/1/2025 (Susp)	80	Solar/Storage	Adams	WA	Warden 115kV Station
TCS-14	9/1/2026	375	Wind/Storage	Garfield	WA	Dry Creek 230kV Station
CS23-06	9/26/2028	220.5	Wind	Whitman	WA	AVAHub23-05 230kV
CS23-12	7/9/2029	199	Storage	Franklin	WA	AVAHub23-04 230kV
CS23-13	6/30/2028	40	Solar	Lincoln	WA	Davenport 115kV
CS23-14	6/30/2028	40	Solar	Spokane	WA	Airway Heights – Silver Lake 115kV

Planning for more than 1,264 MWs of non-Avista owned generation by 2028

Planned Transmission Upgrades

Planned Projects

- Approved and budgeted
- Scheduled in service within study horizon

ERT #	Project Name	Driver	Scope	Status	Included in Model		
					1-year	5-year	10-year
131	Garden Springs Station	Performance & Capacity	Construct <u>new</u> 115kV portion of Garden Springs Station at the existing Garden Springs switching location. New station will terminate Airway Heights – Sunset and Sunset – Westside 115kV transmission lines including the South Fairchild Tap. Construct new 230kV portion of Garden Springs Station including two 250MVA nominal 230/115kV transformers. Construct new 230kV transmission line from Garden Springs to a new switching station, Bluebird, at an interconnection point on the BPA Bell – Coulee #5 230kV transmission line.	Construction		X	X
134	Craig Road Interconnection	Customer Requested	Customer will construct <u>new</u> distribution station. Avista will provide <u>new</u> radial 115kV transmission line from Airway Heights Station as part of the Melville Station project. Project updates the existing Boulder-Ivin #1	Budgeted		X	X

Point-to-Point Customer Data

- **Impacts from Point-to-Point Service**
 - Transmission service impacts
 - Generation impacts
- **Include Firm Transmission Service for Existing Customers**
 - Evaluate transmission forecasts to serve existing customers on the planning horizon
- **Long-Term TSRs Addressed Independently from the System Assessment**

Planning Criteria

- **Applicable Facility Ratings Shall Not be Exceeded**
 - NERC (North American Electric Reliability Corporation) TPL-001-5
 - Thermal and voltage ratings apply
 - Planning does not use emergency ratings
- **WECC Voltage & Frequency Dip Criteria**
 - WECC (Western Electricity Coordinating Council) TPL-001-WECC-CRT-4
- **TP-SPP-01 Transmission System Performance**

Planning Criteria

Category	Initial Condition	Event	Fault Type	Thermal Performance	Voltage Performance	Transient Performance
P0 - No Contingency	Normal System	None	N/A	< 80% Continuous Rating ⁶	0.95 < Avista 115kV < 1.052 ⁷ 1.01 < Avista 230kV < 1.052 ⁸ 0.99 < 500kV < 1.11 ⁹ 0.95 < All Other < 1.05 ¹⁰	N/A
P1 - Single Contingency	Normal System	Loss of one of the following:	3Φ	< 95% Continuous Rating ¹¹	0.95 < Avista 115kV < 1.052 0.95 < Avista 230kV < 1.052 ¹² 0.99 < 500kV < 1.11 0.95 < All Other < 1.05 < 8% deviation (load stations) ¹³	No BES generator shall lose synchronism ¹⁴ Same requirements as P2-P7 ¹⁵
		1. Generator				
		2. Transmission Circuit				
		3. Transformer				
P2 - Single Contingency	Normal System	1. Opening of a line section w/o a fault	N/A	< 95% Continuous Rating ¹¹	0.95 < Avista 115kV < 1.052 0.95 < Avista 230kV < 1.052 ¹² 0.99 < 500kV < 1.11 0.95 < All Other < 1.05 < 8% deviation (load stations) ¹³	Positive damping within 30 seconds
		2. Bus Section Fault	SLG			
		3. Internal Breaker Fault (non-Bus-tie Breaker)	SLG			
		4. Internal Breaker Fault (Bus-tie Breaker)	SLG			
P3 - Multiple Contingency	Loss of generator unit (no System adjustments)	Loss of one of the following:	3Φ	< 95% Continuous Rating ¹¹	0.95 < Avista 115kV < 1.052 0.95 < Avista 230kV < 1.052 0.99 < 500kV < 1.11 0.95 < All Other < 1.05	Positive damping within 30 seconds
		1. Generator				
		2. Transmission Circuit				
		3. Transformer				
P4 - Multiple Contingency (Fault plus stuck breaker)	Normal System	Loss of multiple elements caused by a stuck breaker (non-Bus-tie Breaker) attempting to clear a Fault on one of the following:	SLG	< 95% Continuous Rating ¹¹	0.95 < Avista 115kV < 1.052 0.95 < Avista 230kV < 1.052 0.99 < 500kV < 1.11 0.95 < All Other < 1.05	Positive damping within 30 seconds
		1. Generator				
		2. Transmission Circuit				
		3. Transformer				
		4. Shunt Device				
5. Bus Section						

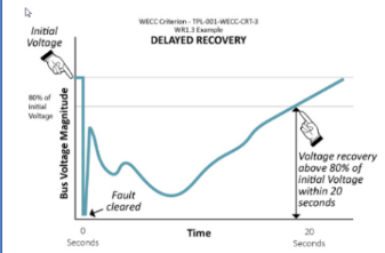

Transmission System Analyses

- Steady State Contingency Analysis
- Spare Equipment Analysis
- Short Circuit Analysis
- Stability Contingency Analysis
- Voltage Stability Analysis

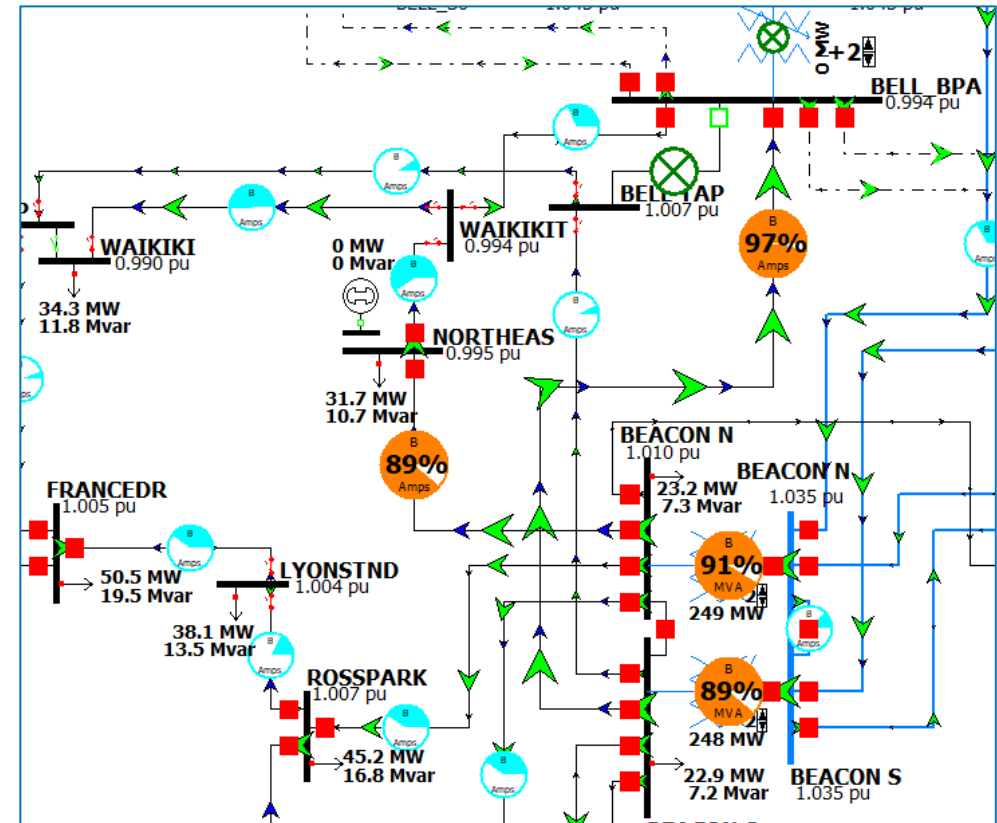

Distribution Planning

Assumptions, Modeling, Criteria, Analyses

Erik Lee | Principal Engineer System Planning

Assessment Overview

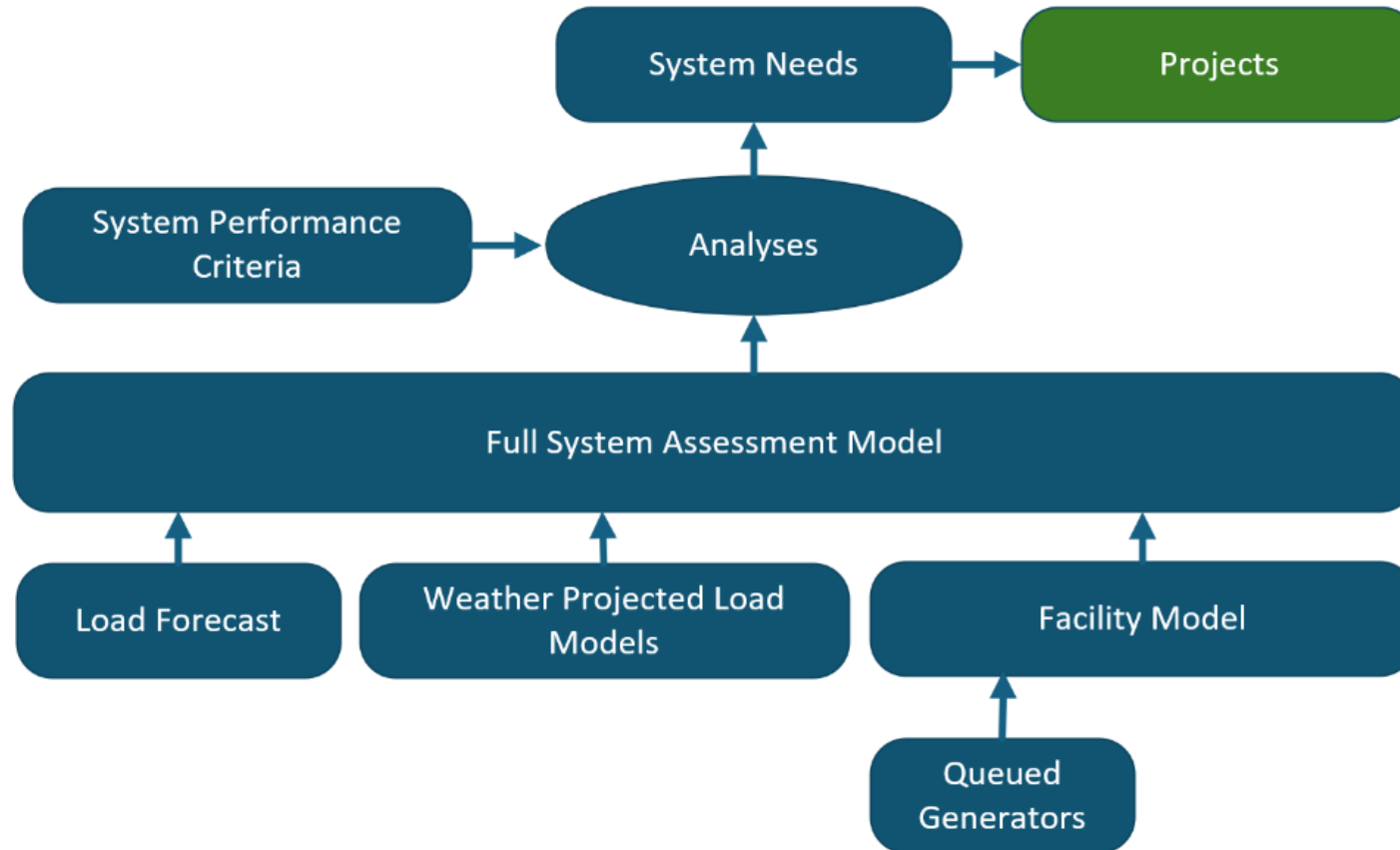

System Conditions / Assumptions

- Facility Model Set to Normal/As-Built Switching State
- Load Forecast: 10 years Using 3 Years Historical Data
- Load Model: 1 in 10 Year Min/Max Temperature Frequency of Occurrence (FO) by Subregion
 - Heavy Summer: Peak Annual Hourly Temperature
 - Heavy Winter: Minimum Annual Hourly Temperature
 - Temperature Curves Adjusted to Regional FO Values (for Summer & Winter)
 - 576 Load Models Driven by Temperature Curves
- Approved Projects are Modeled at Expected Energization Year
 - 10 Year Model

Location	Heavy Summer 1 in 10	Heavy Winter 1 in 10	Data Start
Colville	104F	-18F	2001
Spokane	104F (106F)	-17F (-5F)	1972
Sandpoint	102F	-9F	2004
Pullman/Moscow	101F (103F)	-18F (-14F)	1972
Othello	108F (110F)	-15F (-13F)	1950
Lewiston	108F (110F)	-10F (-2F)	1950
Silver Valley	102F	-14F (-13F)	1950

Temperature value in parentheses is derived using the past 25 years of temperature data

Weather Frequency of Occurrence

- Used NOAA Regional Data
- Identify Peak & Min Temps by Year
- Calculate Number of Years Above/Below Given Temp Value (-50F to 130F) & Express as Percentage of Years Over the Dataset

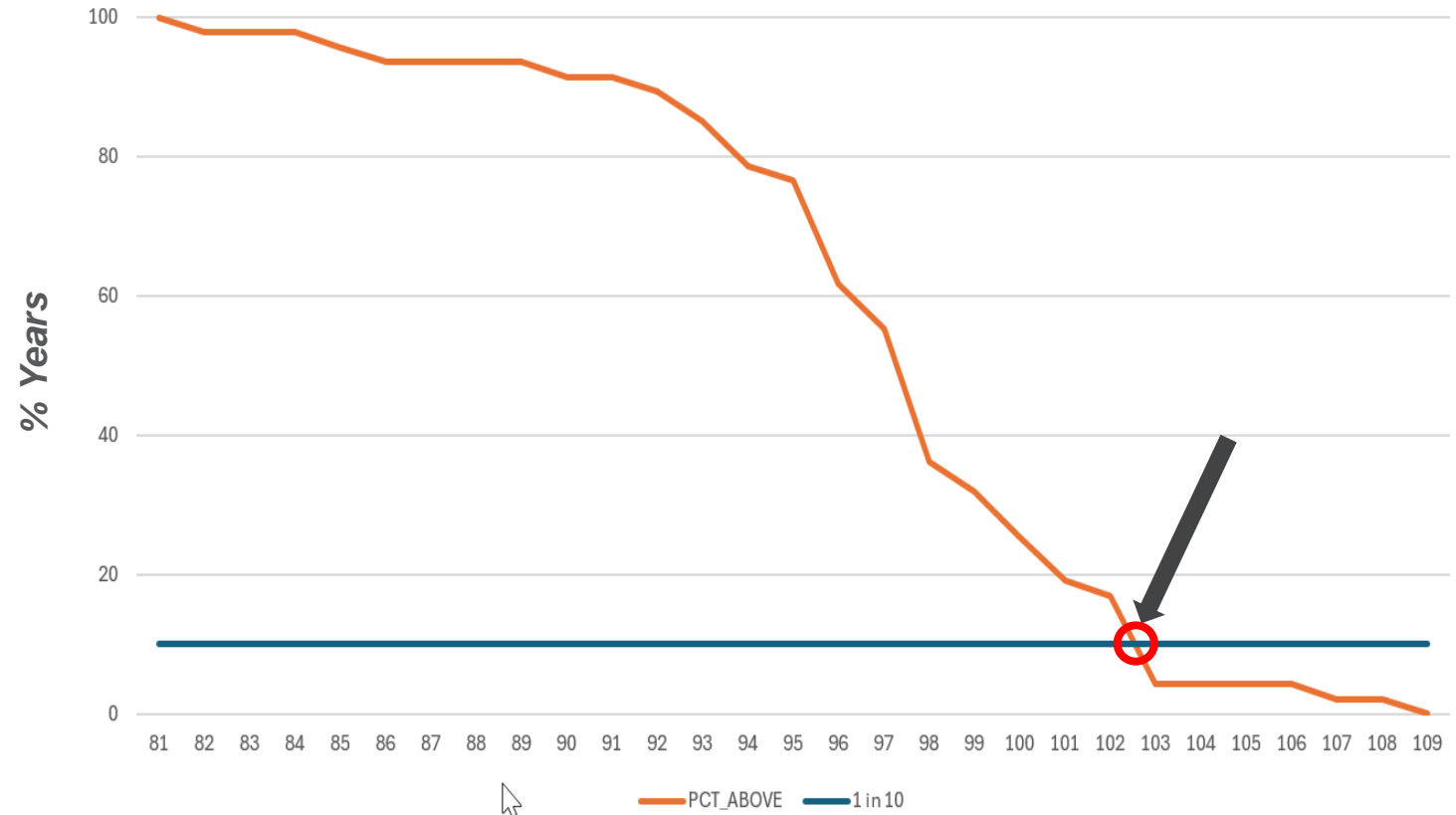

Percentage of Years (Y axis) Above
Given Temperature (X axis)

Weather Adjusted Seasonal Peaks & 576 Models

- Use Frequency of Occurrence Peak/Min Adjusted Annual Regional Weather Curves
- Month/Hour/Day Type Linear Regression Models (576)
 - 12 Month x 24 Hours x2 (Weekday/Weekend)

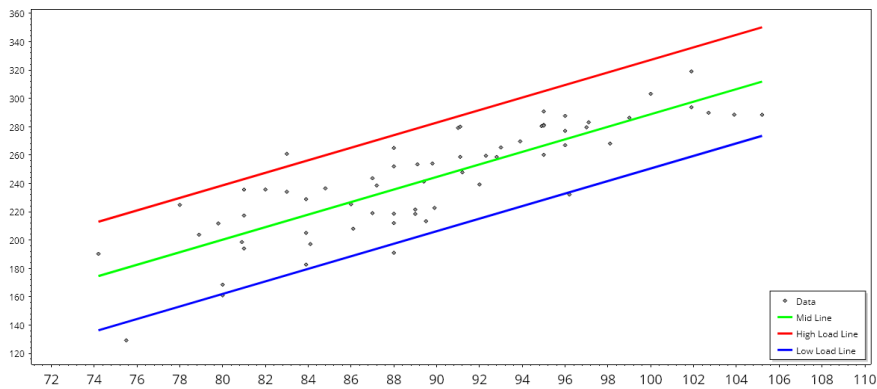

4-5PM July Actuals, Regression, & +/- 1 Standard Deviation Lines

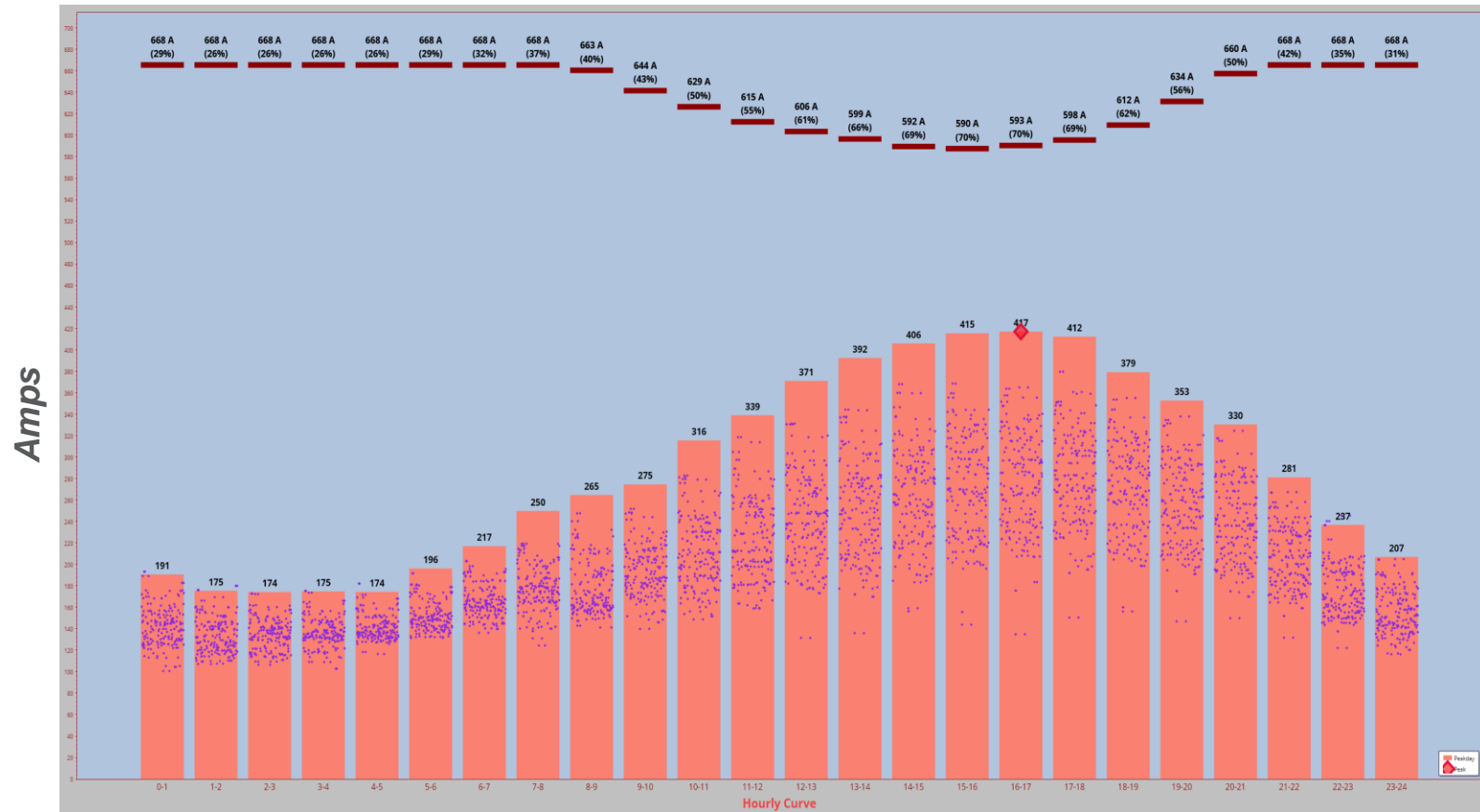

X Axis: Hour of Day (1-24)

Purple Dots: Actual Measurements | Red Bars: Modeled Hourly Loads
Top Bars: Facility Limit Rating

Distribution Load Forecast

- Feeder & Substation Transformer Level
- Typically Use 3 Years of Historical Hourly Average Load Data
- Anomalies Filtered Out (Top Figure)
- Multiple Linear Regression Approach (Bottom Figure)
 - Time Elements (Year, Hour of Day, Day of Week, Month, etc.)
 - Weather as Heating Degree Days & Cooling Degree Days
 - Light-Hours
- Permanent Load Transfers Require Feeder/Station/Region Data Aggregation
 - Proportion Back To Individual Elements

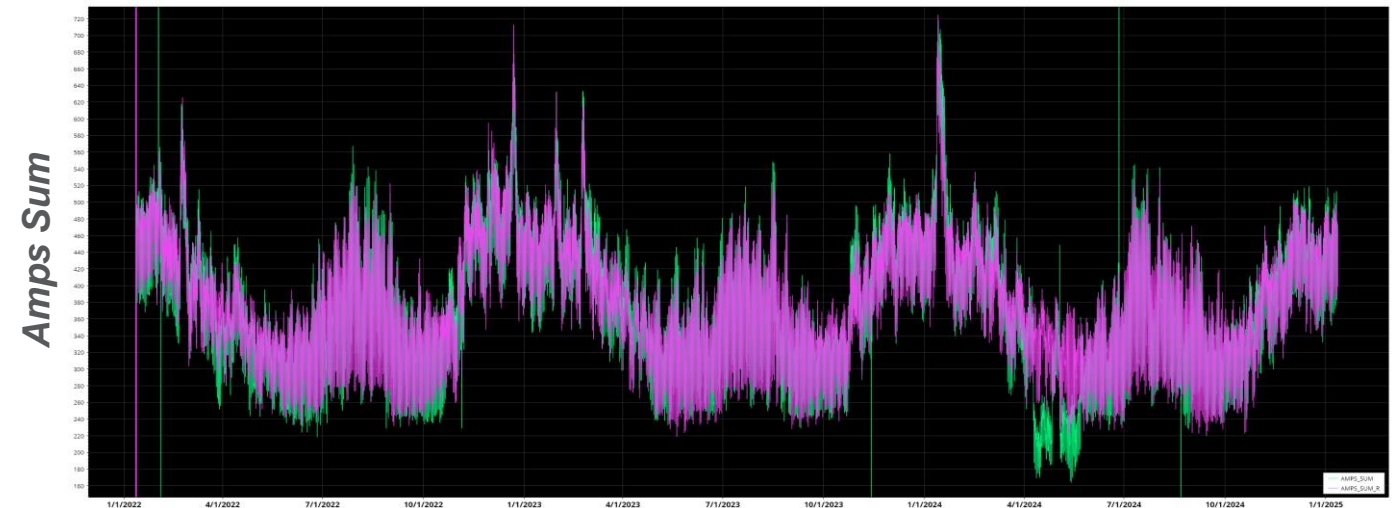
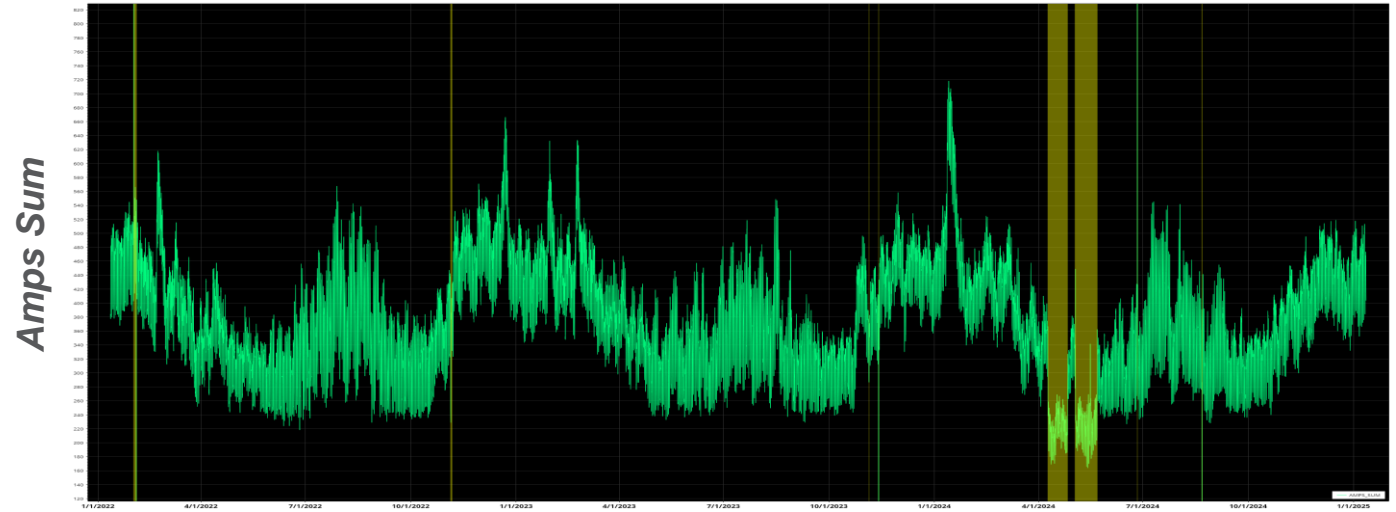

Calendar Time (3 years)

Full Model Development

- **Synergi Electric**
 - Copy of Weekly Model Build
- **Generation**
 - Small Generation (Rooftop PV, Wind) Included in Model
 - Large Distribution-Connected Generators
 - Potential Generation projects in Avista's Interconnection Queue
- **Known Developments (Block Load Additions)**
- **10 Year Forecasted Loads**
 - Using Summer & Winter 1 in 10 Peaks
- **Budgeted & In-Construction Projects**
 - Manually Edited In

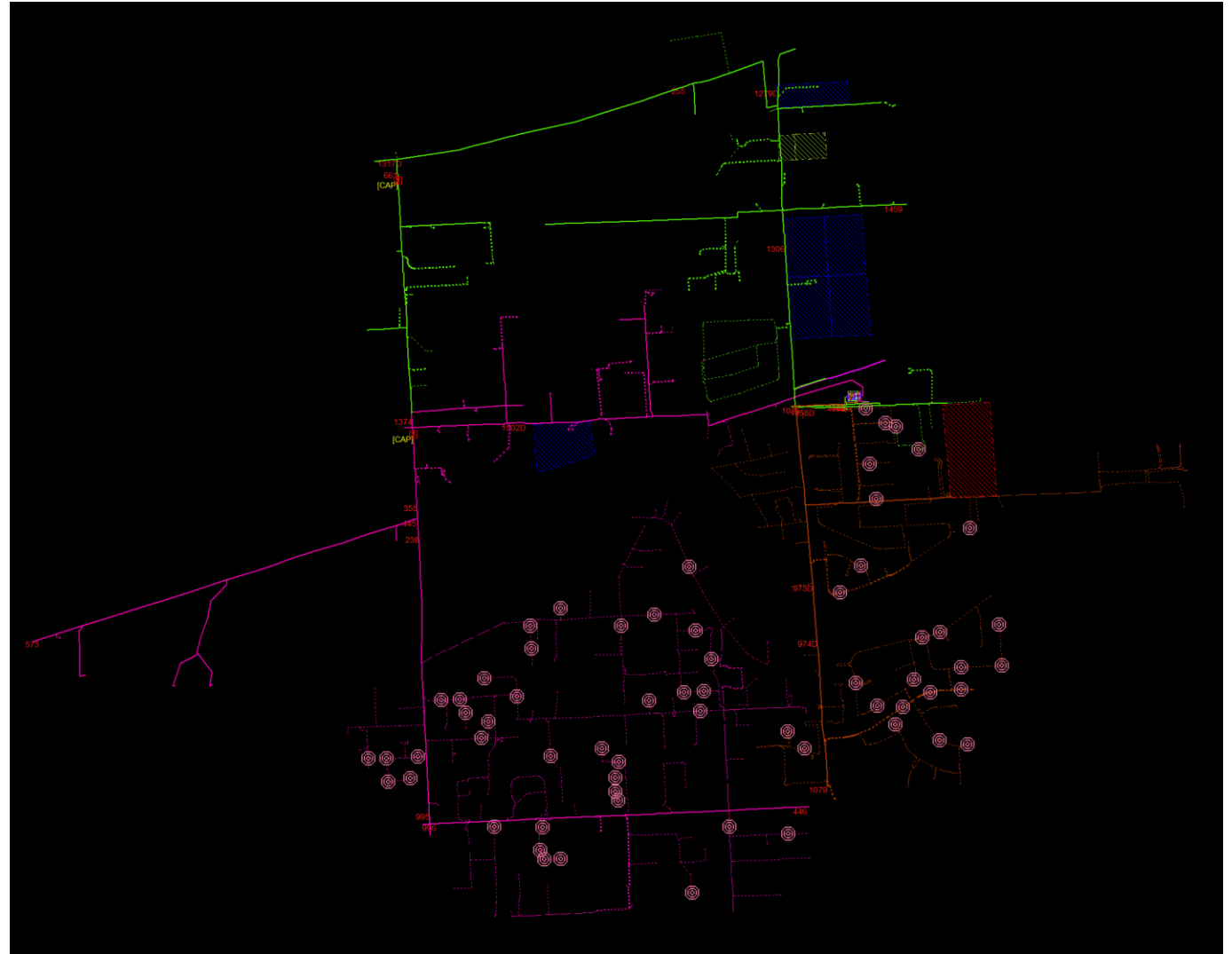

Barker Rd 115kV / 13kV Substation (Synergi Electric)

Distribution Planning

Performance Criteria

Category ²	Outage ³	Thermal Performance	Voltage Performance ⁴	Regulator Performance	Current Imbalance	Voltage Imbalance	Customers Experiencing Interruption ⁵	Customers Experiencing Sustained Outage Longer than 2 Hours ⁶	Notes
D0 - No Contingency	None	< 80% Continuous ⁷	118V < Volt < 127V	-12 < tap < +12	Line loading > 90%: 5% Line loading > 80%: 10% Line loading > 70%: 15% Line loading < 70%: 20%	3%	N/A	N/A	<ul style="list-style-type: none"> Seasonal load transfers can be used
D1 - Feeder Contingency	Loss of one of the following:	< 95% Continuous	114V ⁸ < Volt < 127V < 4V Deviation ⁹	-15 < tap < +15	Line loading > 90%: 10% Line loading < 90%: NA	5%			<ul style="list-style-type: none"> Field switching can be used to restore customers Generator curtailment may be required for restoration
	1. Feeder Lockout						3000 or 10MVA	Suburban: 500 Rural: 3000	
	2. Generator Outage/Off						0	0	
	3. Automatic Transfer Switch Operation						N/A	N/A	
D2 - Multiple Contingency (Common Structure ¹⁰)	Loss of one of the following:	< 95% Continuous	114V < Volt < 127V		None	5%	4000	500	
	1. Loss of two feeders on common structure								
	2. Loss of three feeders on common structure								
D3 - Substation Contingency	Loss of one of the following:	< 95% Continuous	114V < Volt < 127V	-15 < tap < +15	None	5%			<ul style="list-style-type: none"> Feeder breaker and/or regulator bypass is acceptable
	1. Feeder Regulator						3000	0	
	2. Feeder Breaker						3000	0	
	3. Substation Transformer						6000	Suburban: 0 Rural: 1500	

Distribution System Analyses

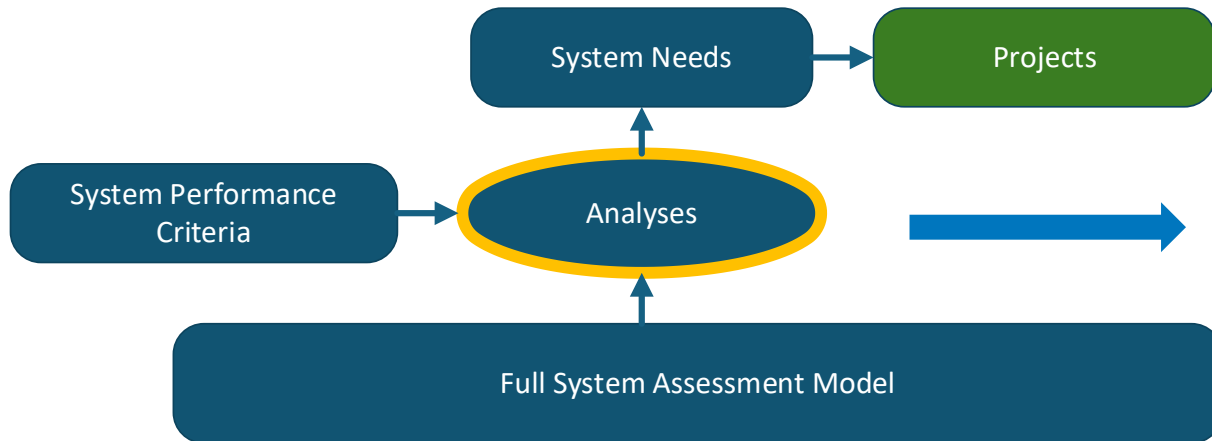

Capacity (Multiyear Load Flow)

Feeder | Substation Transformer | 10 Year Planning Horizon

Phase Current Imbalance

Where we have data

Auto-Transfer Analysis

Ensure ATS failover capacity capability

Contingency Analysis

Development in 2025

Short-Circuit Analysis

Re-evaluate in 2025

Thermal Performance Explanation

Thermal Performance

- Amps (Current) = Heat
- Heat = Degradation
- Heat = Sagging
- Heat = Material Failure
- Heat = Insulation Failure

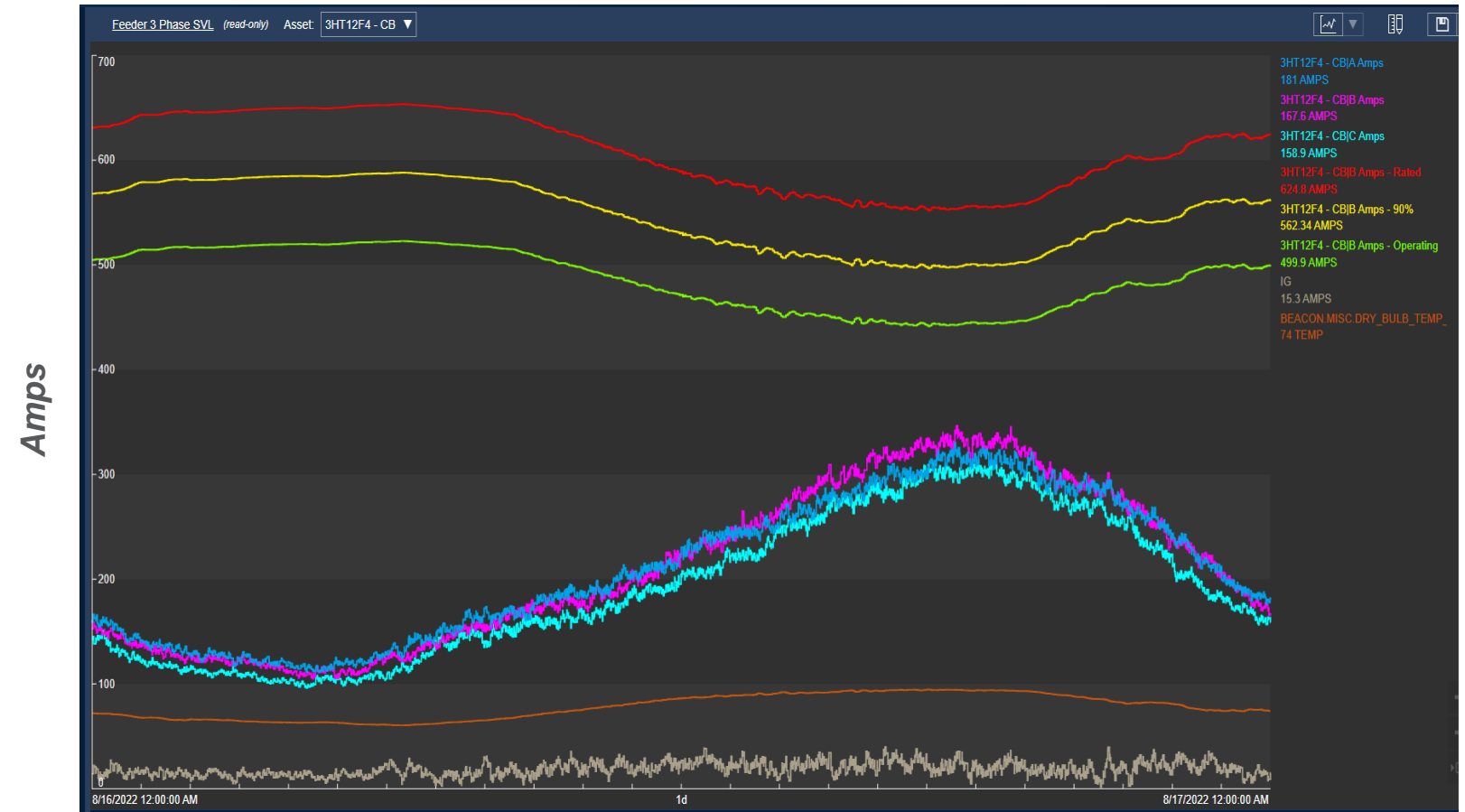

X Axis: Time

Aveva (OSISoft) PI Vision Dashboard

Current Avista Projects

Project Name	Driver	Status
Carlin Bay Substation	Performance & Capacity	Construction
Metro Station Rebuild	Asset Condition	Construction
Valley Station Rebuild	Performance & Capacity	Construction
Prairie Station Rebuild	Performance & Capacity	Construction
Bronx Station Rebuild	Performance & Capacity	Budgeted
Post Falls Station Rebuild	Customer Requested	Budgeted
Melville Station	Performance & Capacity	Budgeted
Bunker Hill Customer Capacity	Customer Requested	Budgeted
Pleasant View Capacity Mitigation	Performance & Capacity	Budgeted
Northeast Capacity Mitigation	Performance & Capacity	Budgeted
Glenrose Capacity Mitigation	Performance & Capacity	Budgeted
Orin Capacity Mitigation	Performance & Capacity	Budgeted
<i>Moscow Capacity Mitigation</i>	<i>Performance & Capacity</i>	<i>Proposed</i>
<i>Lewiston Capacity Mitigation</i>	<i>Performance & Capacity</i>	<i>Proposed</i>

Next Steps

- Develop an approach to using AEG's 2025 DER Potential Study results in the 2025 System Assessment
- Finalize Study Plan
- Perform analyses and identify system needs
- Topic suggestions email: DistributionPlanning@avistacorp.com



Avista's O'Gara 115kV / 13kV Substation, South of Harrison, ID

Q&A